

STREAMING EXTENSION OF GEN2 COMMUNICATION PROTOCOL

VER. 2.1, MAY 8, 2023

BACKSCATTER COMMUNICATION RESEARCH CONSORTIUM

KEIO UNIVERSITY

1 Overview

This document proposes an extension of ISO/IEC 18000-63 (2015) specification (hereafter referred to as Gen2)[1] or a new stream of protocol to enable concurrent sensor data streaming from multiple radio frequency (RF) tags with multiple subcarrier channels. The Gen2 streaming system comprises a reader/writer and a single or a group of streaming enabled Gen2 tags (hereafter referred to as reader and stream tags, respectively), as shown in Figure 1.

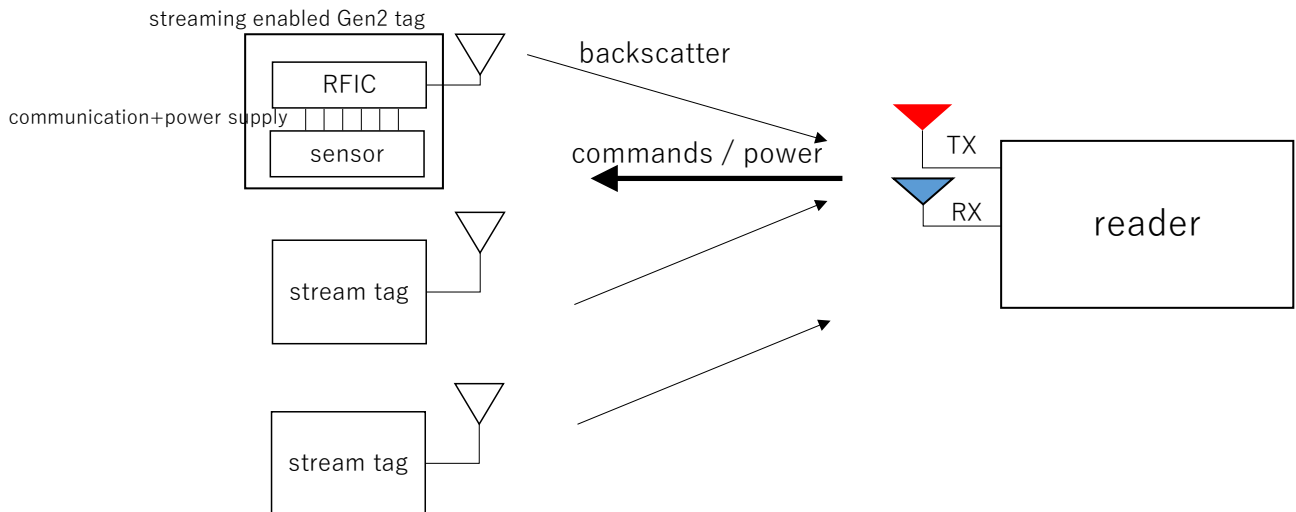

Figure 1 Streaming Gen2 system composition

As shown in Figure 1, a stream tag comprises an RF integrated circuit (RFIC) and a sensor connected to RFIC through, for example, the serial peripheral interface (SPI). The RFIC handles the communication with the reader using an extended Gen2 protocol. Additionally, it provides power to the sensor.

The Miller encoded subcarrier is extensively used in commercial Gen2 RFID systems. However, only one tag responds to its reader at a time. In the Gen2 streaming system, each stream tag in the view field of the reader is assigned a dedicated subcarrier channel by the reader, and the sensor data can be concurrently streamed using the subcarriers. An overview of the communication protocol is explained in the next subsection.

1.1 Communication protocol

The high-level overview of the communication protocol is shown in Figure 2. The communication between the reader and stream tags progresses via the following three stages:

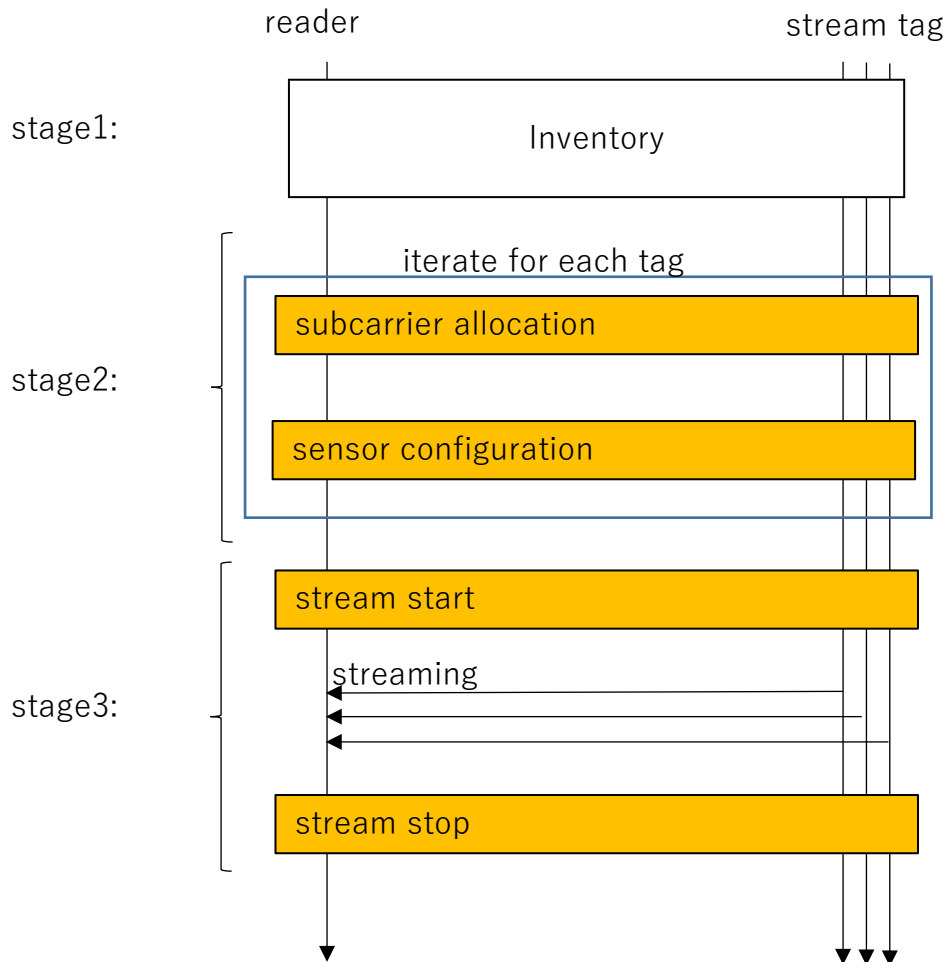

Figure 2 Communication protocol between the reader and stream tags. Shaded blocks represent an additional protocol for Gen2

■ **Stage 1 Inventory:** During this stage, the reader inventories each of both the stream tags and standard Gen2 tags using Gen2 SELECT, QUERY, and related commands. Although the algorithm for subsequent subcarrier allocation depends on the reader's implementation, collection of received signal strength indicator (RSSI) during the inventory process is recommended. The practice adopted in this document is to assign the weak RSSI subcarrier to subcarriers close to powering continuous waves [3]. This is done to reduce mutual interference caused by subcarrier harmonics.

■ **Stage 2 Subcarrier assignment and allocation:** A unique subcarrier is assigned¹ and allocated to each stream tag using Gen2 WRITE command to specific memory addresses. Each stream tag is given a zone ID that distinguishes between the streaming zones. When the subcarrier is allocated, each stream tag is placed into the DCO_LOCKED state, essentially awaiting the STREAM_START command.

After the subcarrier allocation, the sensor in a stream tag can be configured using an RFIC-sensor interface such as SPI.

■ **Stage 3 Streaming:** To start streaming from all stream sensors, the reader sends a STREAM_START command, which is chosen from one of the Gen2 RFU commands. Optionally, a STREAM_STOP command can be used to stop the streaming from the stream tags with a specified zone ID.

Each stream tag should be capable of inventory, read, and write operations in the existing Gen2. In addition to the present communication protocol, the stream tag should be capable of handling subsequent subcarrier channel allocation and data streaming, as shown in Figure 3.

¹ Assignment means the determination of subcarrier frequency chosen for a particular stream tag. Whereas, allocation means the communication between the reader and stream tag that enables the stream tag to set the assigned subcarrier.

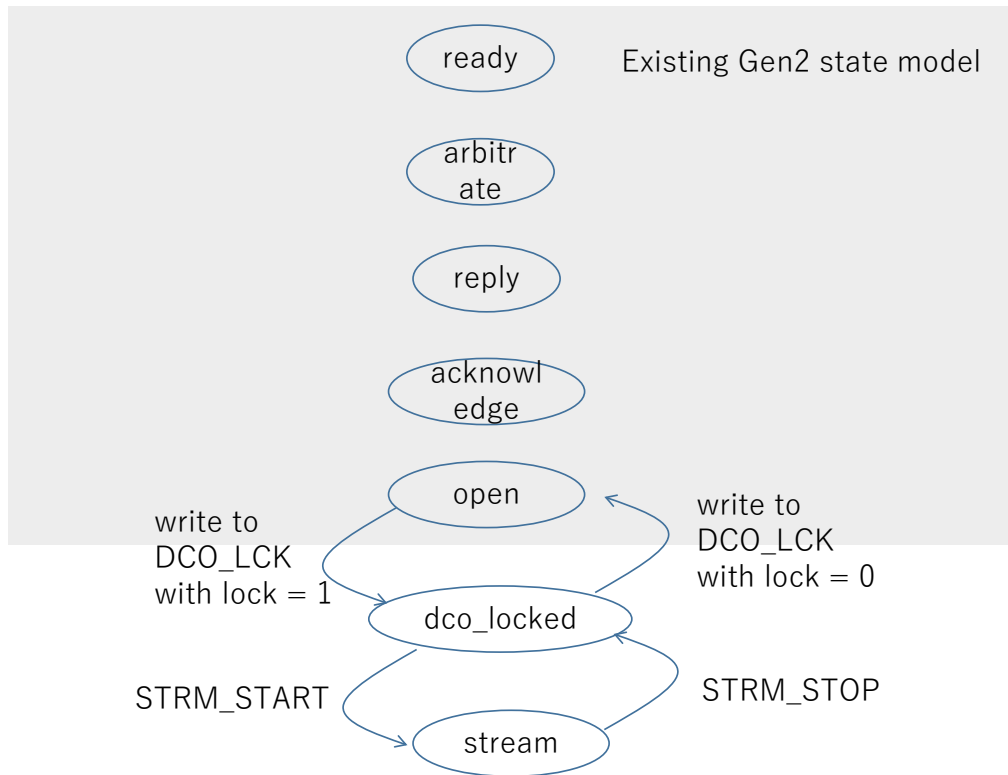

Figure 3 State transition of a stream tag

2 Communication protocol detail

2.1 Subcarrier frequency and symbol definition

In Stage 3 of communication, one encoded symbol should be represented with at least two cycles of subcarrier. If a symbol is represented with only one cycle of subcarrier, it is baseband coding. The subcarrier frequencies in the stream Gen2 system comprise integer multiples of the base subcarrier frequency, as shown in Figure 4. In the figure, three base subcarrier frequencies are denoted by subcarrier 1 with $m_s = 1, 2, 3$. Notably, this coding is applied only to Stage 3; the standardized Gen2 coding and modulation specified by the reader can be employed in Stages 1 and 2.

For example, when the symbol rate in the streaming phase is 10 kbps, $m_s = 2$, and no coding is introduced, the frequencies of the subcarriers 1, 2, and 3 are 20, 40, and 60 kHz, respectively.

To facilitate the demodulation in the reader, we employ Miller encoding or differential Miller encoding along with subcarrier coding.

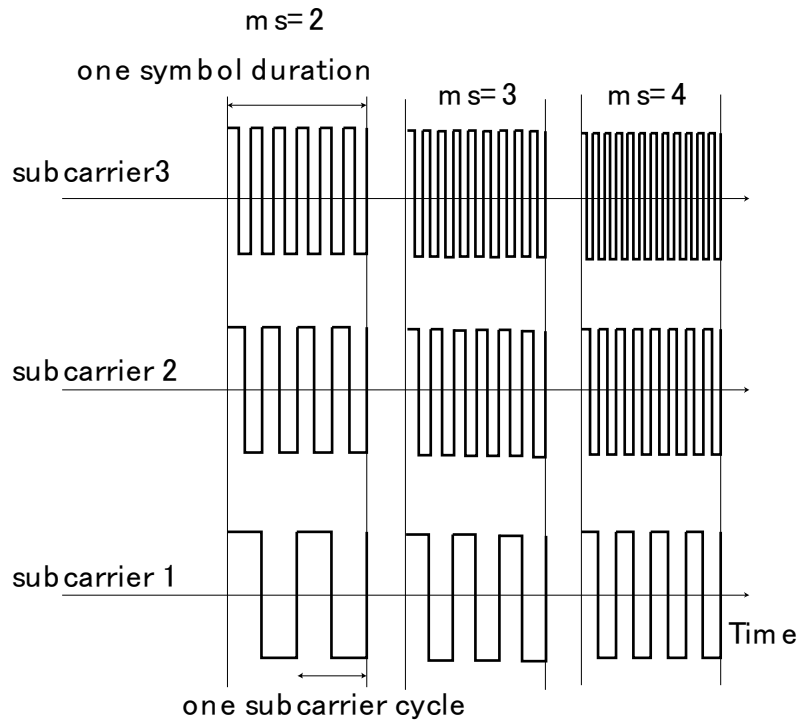

Figure 4 Subcarrier frequency and symbol

The state diagram of Miller encoding is shown in Figure 5.

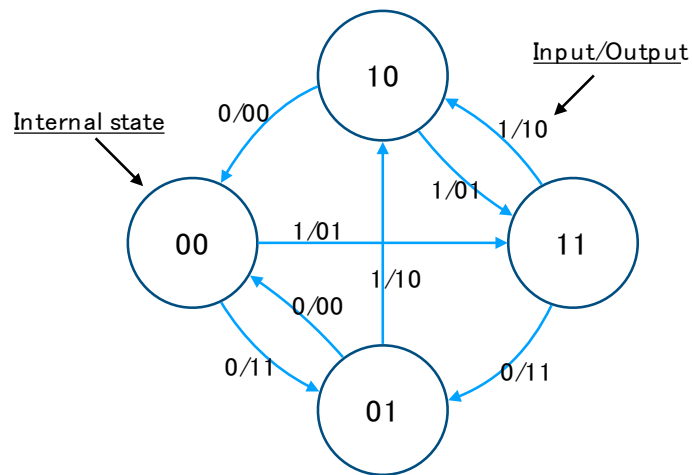
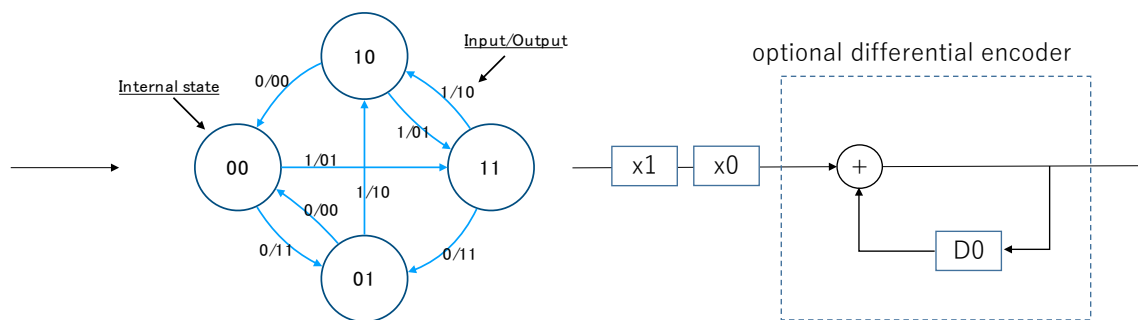

Figure 5 Miller coding state transition

The subcarrier is XORed with Miller encoded baseband signal except for the preamble, as explained below.

The differential Miller encoding state model and differential encoder are shown in Figure 6.



D0 shall be set to zero at the beginning of each frame

Figure 6 Differential Miller coding

2.2 Streaming frame

A stream tag comprises a continuous frame, shown in Figure 7, to transfer streaming data to the reader in Stage 3. The leading 5 bits are the preamble without Miller encoding. The rest of the frame should be encoded with Miller or differential Miller coding. Furthermore, the rest of the frame should produce the CRC-16, as follows.

- Generation polynomial is $x^{16} + x^{12} + x^5 + 1$
- 16 bits register preloaded with 0xFFFF
- Data MSB was input and all the data clocked
- The final 16 bits inverted to obtain CRC-16

For checking, the register filled with 0xFFFF, all the data including CRC-16 clocked, and checked if the output is 0x1D0F

It should be noted that zone ID is specified by the reader, whereas sequence ID is the frame ID automatically incremented by one in each frame. The data length N is specified by the reader with the STR_CNT register.

Preamble	Zone ID	Sequence ID	Data	CRC16
5 bit equivalent	3 bits	8 bit (0-255 sequential data)	$N \times 8$ bits	16 bits
1010101010	001	255		

Figure 7 Return link frame structure in stage 3

2.3 Subcarrier allocation and bit rate configuration

Generally, the RFIC design to generate subcarrier frequency in a stream tag falls under the scope of the manufacturer. However, there is a proven way to generate specified subcarrier frequency with a relatively slow clock rate of the master clock in RFIC is by adjusting the frequency of the oscillator in a tag to be an integer multiple of designated subcarrier frequency; this is done using a digitally controlled ring oscillator (DCRO). Alternatively, subcarrier frequency can be produced by decimating a single master clock. However, in such a design, a high subcarrier frequency tends to involve bias, which may violate the subcarrier accuracy requirement.

The subcarrier frequency produced by a stream tag does not immediately match the specified frequency owing to the instability of the DCRO clock. Therefore, the proposed communication protocol performs an iterative adjustment wherein two commands, DCO_CNT and SUB_DIV, are used repeatedly. The DCO_CNT command specifies the clock frequency, whereas the SUB_DIV command specifies the decimation ratio to both produce a subcarrier from the DCRO clock and define the bitrate.

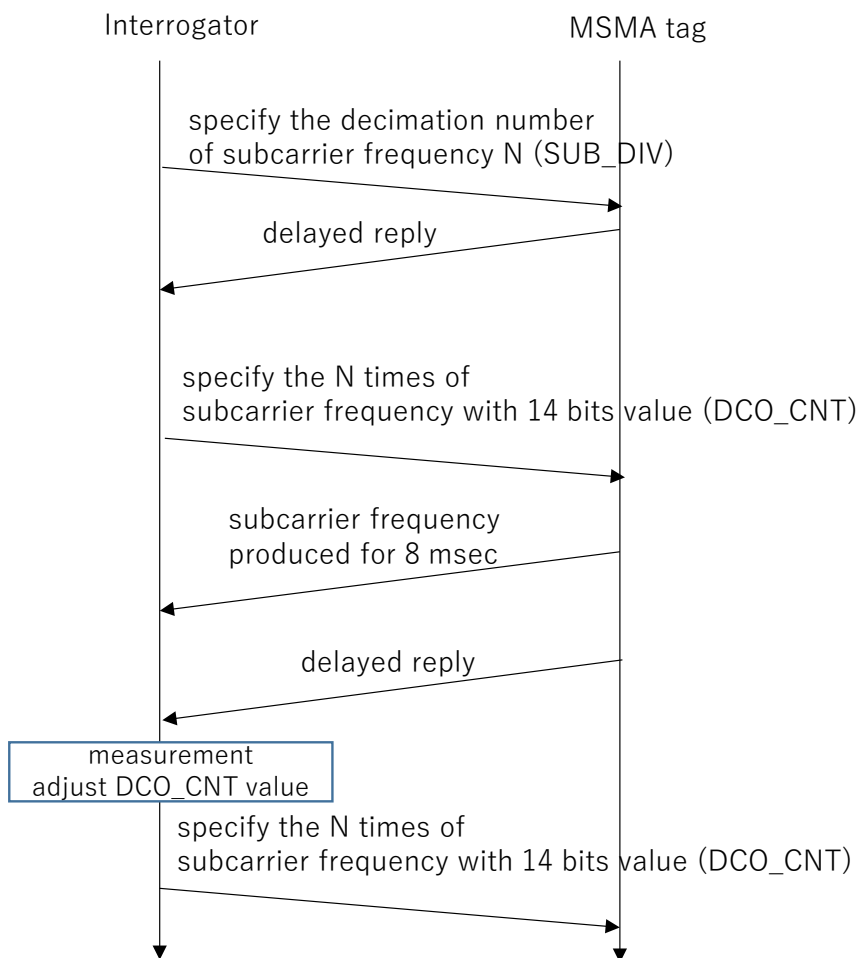

Figure 8 Iterative subcarrier frequency adjustment

The 14-bit DCRO value comprises overlapped coarse, middle, and fine registers (Figure 9).

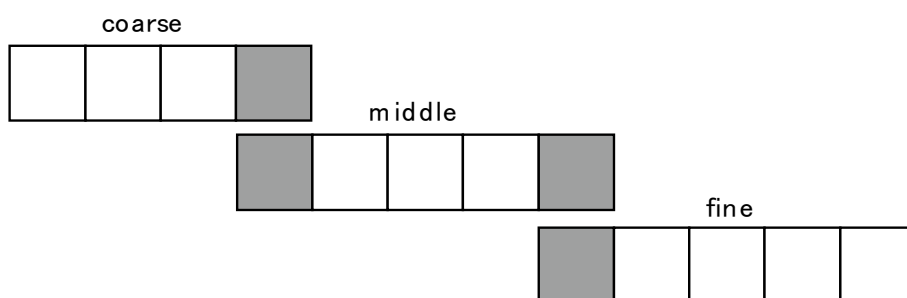

Figure 9 Overlapped DCO_CNT register value

The 14-bit value X relates to the actual frequency as follows.

$$f = 400 X + 691200$$

Consequently, one subcarrier frequency can be represented in general with four patterns of register values, thereby allowing some errors in the adjusting accuracy of the DCRO (Figure 10).

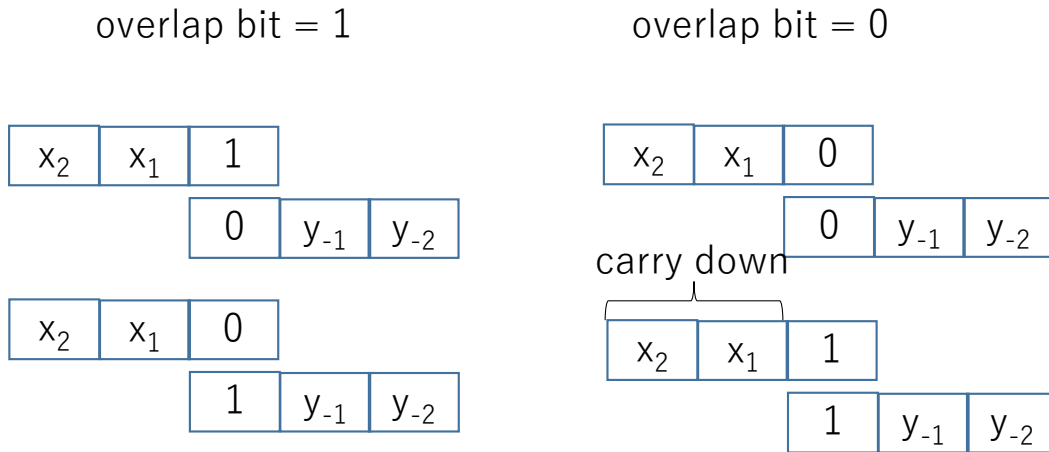

Figure 10 Candidates to represent one overlap bit

However, the increase in the subcarrier frequency against a unit increase in each register value cannot exceed 2.0 because such a case will produce a gap in the subcarrier frequency that cannot be compensated (Figure 11).

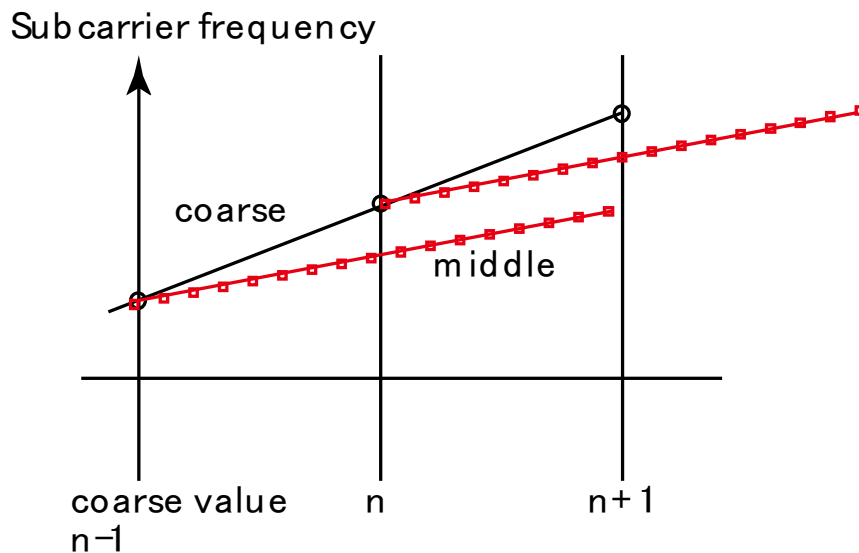

Figure 11 Slopes of each DCO value cannot be different by more than two times. This figure depicts the cases of coarse and middle registers.

The available subcarrier frequency and bitrate are listed in Table 1. The lowest subcarrier frequency, 100 kHz, is chosen to avoid interference from the powering continuous wave from the reader. The lowest symbol rate is confined to 10 kbps, as lower symbol rate links are affected by DCRO frequency fluctuation.

Table 1 Subcarrier and bitrate allocation

DCO control word							divider control word			baseband bit rate (B bits (6bits))				
C	M	F	Code (14bits)			DCO Clock (MHz)	dividing ratio	Dividing ratio (3 bits)	sub. Freq (kHz)	120kbps	100kbps	40kbps	20kbps	10kbps
			C	M	F									
7	29	16	0111	11101	10000	1.6	16	100	100					0001010
10	31	16	1010	11111	10000	1.92	16	100	120				0000110	0001100
3	18	16	0011	10010	10000	1.12	8	011	140					0001110
4	27	16	0100	11011	10000	1.28	8	011	160			0000100	0001000	0010000
6	20	16	0110	10100	10000	1.44	8	011	180					0010010
7	29	16	0111	11101	10000	1.6	8	011	200		0000010		0001010	0010100
9	22	16	1001	10110	10000	1.76	8	011	220					0010110
10	31	16	1010	11111	10000	1.92	8	011	240	0000010		0000110	0001100	0011000
2	21	24	0010	10101	11000	1.04	4	010	260					0011010
3	18	16	0011	10010	10000	1.12	4	010	280				0001110	0011100
3	30	24	0011	11110	11000	1.2	4	010	300					0011110
4	27	16	0100	11011	10000	1.28	4	010	320			0001000	0010000	0100000
5	23	24	0101	10111	11000	1.36	4	010	340					0100010
6	20	16	0110	10100	10000	1.44	4	010	360				0010010	0100100
7	16	24	0111	10000	11000	1.52	4	010	380					0100110
7	29	16	0111	11101	10000	1.6	4	010	400		0000100	0001010	0010100	0101000
8	25	24	1000	11001	11000	1.68	4	010	420					0101001
9	22	16	1001	10110	10000	1.76	4	010	440				0010110	0101100
10	18	24	1010	10010	11000	1.84	4	010	460					0101110
10	31	16	1010	11111	10000	1.92	4	010	480	0000100		0001100	0011000	0110000
11	27	24	1011	11011	11000	2	4	010	500					0110010
2	21	24	0010	10101	11000	1.04	2	001	520				0011010	0110100
2	27	28	0010	11011	11100	1.08	2	001	540					0110110
3	18	16	0011	10010	10000	1.12	2	001	560			0001110	0011100	0111000
3	24	20	0011	11000	10100	1.16	2	001	580					0111010
3	30	24	0011	11110	11000	1.2	2	001	600		0000110		0011110	0111100
4	20	28	0100	10100	11100	1.24	2	001	620					0111110

An example of subcarrier frequency allocation is explained below.

- i. The reader writes to the SUB_DIV register as 4 division = b100. The bitrate value in the word does not matter in this particular SUB_DIV.
- ii. The interrogator writes to the DCO_CNT register with an appropriate frequency value.
- iii. The tag replies with the DCO_CNT register divided by four subcarrier frequencies for 8 ms.
- iv. The reader samples the information regarding 1/4th DCO frequency and issues an updated DCO_CNT value to compensate for the error.

Example:

Assuming that a reader wants to allocate a 200 kHz subcarrier to a stream tag after inventory, the DCRO frequency of the stream tag should be 1.6 MHz according to Table 1.

For DCO control, the interrogator expects to receive a 400 kHz (1/4th DCO) subcarrier for 8 ms after issuing a DCO_CTL.

- i. The DCO_CTL is 0111 11101 10000. Suppose that the received subcarrier is 404000 Hz, which is approximately 1 % higher than the designated frequency. Therefore, the interrogator needs to lower the tag's clock by approximately 1 %.
- ii. The interrogator knows that the DCRO frequency is 1.6 MHz and the received subcarrier frequency is multiplied by four. This yields $1616 = 404 \times 4$ kHz, which is 16 kHz higher than the designated frequency. The DCRO frequency can be adjusted with 0.4 kHz resolution for 1 bit of DCRO fine division (5 bits from LSB (the Least Significant Bit)).
- iii. The bias of 16 kHz can be compensated with $16/0.4 = 40 = 0 \times 28 = \text{b}0010\ 1000$, which is subtracted from the original DCO_CNL = 0111 11101 10000. This yields 0111 11100 01000.

2.4 Writing configuration with Gen2 WRITE command

The reader assigns and allocates subcarriers to stream tags and configures their sensors using Gen2 WRITE command. The structure of a WRITE command is shown in Figure 12. WordPtr uses Extensible Bit Vectors defined in Gen2. Special register addresses for subcarrier allocation and sensor configuration are specified.

Write (8 bit)	Membank	WordPtr	Data (XORed with handle)	Handle	CRC16
11000011	2 bits (11:user)	(EBV)			16 bits

Figure 12 Gen2 WRITE command

The response from a tag to the reader after receiving a WRITE command is as follows. Upon receiving the WRITE command, a tag responds with the following delayed reply. When an MSMA tag fails to perform the instructed write or configure, it replies with Success/Fail = 1 with a proper error code defined in Annex I of [1].

Preamble	Header	Handle/Error code	CRC16
10 bits	1 bit	16 bits	16 bits
4M/BLF + 010111	0:success	Handle	
4M/BLF + 010111	1:fail	Error code	

The special user memory addresses to stream tag configurations are defined in Table 2. The values should be stored as MSB first byte order. The implementation of the special memory address can be RFIC and/or vendor dependent.

Table 2 Special register assignment

Memory alias	Description	Memory WordPtr
SPI_WRITE	Writes a byte data to the SPI interface	80H
DCO_CNT	Sets the subcarrier frequency	81H
SUB_DIV	Sets the division number of tag clock and bitrate of the subcarrier	82H
SPI_INST	Sets the write and read instruction words used in the SPI interface	83H
STR_CNT	Specifies the leading address and number of bytes for the sensor to read. Zone ID can also be specified with this command	84H
DCO_LCK	DCO frequency lock and unlock. DOC unlock state MSMA tags do not produce subcarrier streaming	85H

SPI_CNTL	To accommodate many types of SPI sensors, the SPI interface is configured through this register	87H
GPIO_CNTL	To trigger the external sensors and devices, the output port can be toggled by writing to this register	88H

SPI_WRITE (80 H)

The high byte and low byte are the address and data to be written, respectively. The tag uses a sensor-specific write command specified in the SPI_INST register (for example 0x0A, in the case of ADXL). Depending on the type of sensor, the configuration of the sensor is obtained through SPI by writing to the SPI_WRITE register.

15	14	13	12	11	10	9	8	7	6	5	4	3	2	1	0
Address								Data							

DCO_CNT (81 H)

15	14	13	12	11	10	9	8	7	6	5	4	3	2	1	0
X	X	C3	C2	C1	C0	M4	M3	M2	M1	M0	F4	F3	F2	F1	F0

Explained in subsection 1.4.

SUB_DIV (82 H)

15	14	13	12	11	10	9	8	7	6	5	4	3	2	1	0
X	X	X	X	X	X	S2	S1	S0	B6	B5	B4	B3	B2	B1	B0

S2, S1, and S0 : Subcarrier divider control words;

bit rate : B0–B6: bitrate divider control words

SPI_INST (83 H)

This word defines the WRITE and READ command bytes for SPI communication. High 8 bits for WRITE and low 8 bits for READ sensor and RFIC communication are shown in Figure 7; for ADXL362, they are $0 \times 0A$ and $0 \times 0B$, respectively.

15	14	13	12	11	10	9	8	7	6	5	4	3	2	1	0
$0 \times 0A$								$0 \times 0B$							

STR_CNT (84 H)

This word defines the data to be read from the RFIC. The high 8 bits (15:8) is the starting address. Bits 7:4 is the number of bytes minus 1² to be read. For example, if we read 2 bytes of data, the bits 7:4 shall be 1. bit 3 is to select the antenna and bits 2–0 is to select the ZONE ID. For ADXL362 to read XDATA, YDATA, ZDATA, TEMP (total $16 \times 4 = 64$ bits = 8 bytes).

Additionally, STR_CNT is used to read the SPI register value by the Gen2 Read command, as explained in the SPI_READ subsection. Although the SPI register is usually bound by a byte, Gen2 READ always returns two bytes (one word) of data. Therefore, the number of bytes should be an odd number, such as 1, 3, 5, and the second byte should be discarded by the interrogator.

15	14	13	12	11	10	9	8	7	6	5	4	3	2	1	0
Address								# of bytes to read			RFU	ZONE ID			
0×08								1000			0	001			

DCO_LCK (85 H)

To avoid unexpected or accidental streaming from background stream tags, the reader should explicitly report the completion of subcarrier allocation to the stream tags. This completes their subcarrier allocation by writing the lock or unlock bool value, zone ID, and coding method to the DCO_LCK register. The default value of the lock flag when a tag wakes up is “unlock”. A stream tag does not start streaming even upon receiving the

² This “minus 1” is to specify up to 16 bytes of data instead of 15 bytes.

STRM_START command if its lock flag is “unlock” or its zone ID does not match the specified zone ID in STRM_START.

15–10	9	8	7	6	5	4	3	2–0	
RFU	Target sensor SPI address		coding option ³			RFU	RFU	Lock flag Lock	RFU
X	Depend on the choice of RFIC		1 = Miller 3 = Miller differential encoding					0:false 1:true	

Response to writing to the DCO_LCK register is given as follows.

Preamble	Success/Fail	Handle	CRC16
10 bits	1 bit	16 bits	16 bits
4M/BLF + 010111	0:success 1:Error		

SPI_CNTRL(87H)

This word defines the behavior settings of the SPI interface for various sensors. The default value at reset is 0x0000. The register value is given as follows.

15	14	13	12	11	10	9	8	7	6	5	4	3	2	1	0
RFU												ASSL	ACC_ OFF	SPI_ MODE	
0												0	0	00	

Bit 3: ASSL (active slave select level), which is chip select (CS) status for an active slave device.

³ Coding options 0 and 2 are used for experimental convolutional coding.

0: Active L level, 1: Active H level

Bit 2: ACC_OFF (Auto Command Code OFF)

0: The command code defined by SPI_INST is automatically added to the SPI Write/Read sequence.

1: The command code defined by SPI_INST is NOT automatically added in the SPI Write/Read sequence.

Bit 1, 0: SPI_MODE, which specifies the operation mode (clock polarity and phase) in SPI communication. CPOL and CPHA should be set by the RFIC to the following values.

SPI mode	CPOL	CPHA	Data shift timing	Data sampling timing
00	0	0	SCK falling ddge	SCK rising edge
01	0	1	SCK rising edge	SCK falling edge
10	1	0	SCK rising edge	SCK falling edge
11	1	1	SCK falling edge	SCK rising edge

CPOL: clock polarity

CPOL = 0 is a CS that idles at 0

CPOL = 1 is a CS that idles at 1.

CPHA: Clock phase

CPHA determines the timing (i.e. phase) of the data bits relative to the clock pulses.

GPIO_CTRL(88H)

This word sets the external GPIO value as OUTPUT. The number of GPIO ports depends on the available PADS. As a tentative value, the following defines four GPIO ports.

15-4	3	2	1	0
RFU	GPIO 3	GPIO 2	GPIO 1	GPIO 0
0	0	0	0	0

Bit 3: GPIO port 3 High/Low (default pull down)

Bit 2: GPIO port 2 High/Low (default pull down)

Bit 1: GPIO port 1 High/Low (default pull down)

Bit 0: GPIO port 0 High/Low (default pull down)

DEMO_CLK(8AH)

This word sets the bitrate of the interrogator-to-tag link for StreamStop.

15-8	7-0
RFU	Division
0x0A	0x28 (default value)

Division: The divisor to produce the subcarrier synchronized decimation to match 10 kbps downlink. The default value is 40 = 0x28, which can only work with 400 kHz subcarrier frequency. If subcarrier frequency is 240 kbps, Divisor shall be 24 = 0x08. This register shall be set before issuing a StreamStart command.

2.5 SPI_READ with Gen2 READ command

SPI registers can be read by a combination of STR_CTL(84H) and Gen2 READ commands. Before any reading of the SPI register, the register address should be specified by STR_CTL (84H). The register data are moved to the two bytes buffers 8CH to 8FH (2 bytes × 4 = 4 words = 8 bytes).

A Gen2 Read command for specifying the special address of USER memory 8CH (EVB 1000 0001 0000 1100) is translated as an instruction to read an SPI memory. If the destination sensor is capable of reading up to two words, the LSB should be the data of the specific register. If the sensor is not capable of reading multiple bytes, the second byte is padded with zeros.

READ	MEMBANK	WORDPTR	WordCount	RN	CRC
------	---------	---------	-----------	----	-----

8	2	EBV (2 bytes)	8	16 bits	16
11000010	11:USER	8CH	Number of words to read (from 1 to 4)	handle	CRC-16

Note that WORDPTR should always be a fixed value. We use 8CH but it can be RFIC manufacture/vendor dependent. It cannot be 8D, 8E, or 8F even when we read multiple words. WordPtr format of 8CH is as follows.

Second byte		First byte	
7	6-0	7	6-0
1	000 0001	0	000 1100

Tag reply to a successful Read command follows the Gen2 protocol and is given as follows.

Header	Memory Words	RN	CRC
8	1 word	16 bits	16
0	Data	handle	CRC-16

2.6 Sensor data streaming SPI interface exchange

The RFIC in a stream tag should collect sensor data through the SPI interface and plug the data into the streaming frame. The data obtained from a sensor are synchronously transferred to the backscatter modulator, as shown in Figure 15.

This can be done by providing the bitrate-level CLK signal from the RFIC and sensor. Furthermore, the SPI sensor should have the capability to stream continuously.

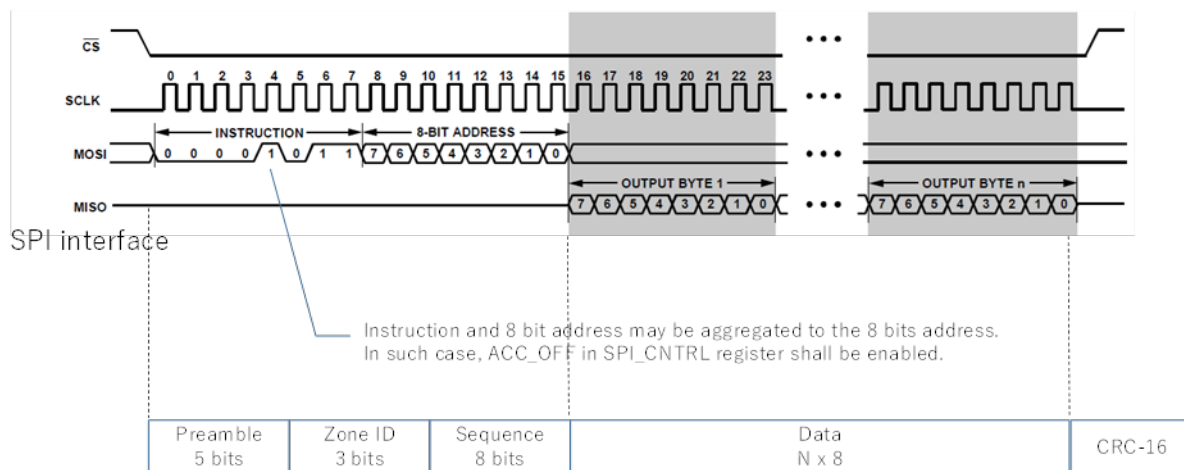

Backscatter link

Figure 13 Sensor data encapsulation in the streaming stage

2.7 Start streaming

This command triggers the streaming from the designated interrogation zone, which is specified using the zone ID. The command bits use one of the RFU commands of Gen2, as given below.

Command (STRM_START)	Zone ID	CRC
8	3	CRC-5
11011010	zone ID	CRC-5

STRM_START should be preceded by FrameSync of Gen2. The selection of the embed sensors or the external analog sensor should be specified by writing to the DCO_LCK register. Generally, the streaming start command is issued repeatedly for two or three times to avoid any stream tag from failing to start. Stream tags, whose Zone IDs are different from the Zone ID in a stream start command, continue to remain in the DCO_LCK state, as shown in Figure 3.

2.8 Stream stop

The reader can suspend ongoing streaming from a group of stream tags that belong to a specified Zone ID. Frame_START and Frame END are demanded for tags to prepare for the demodulation. The technical discussion of full duplex backscatter is provided in [5]

Frame_START	Command (STRM_STOP)	Zone ID	CRC	Frame END
6	8	3	CRC-5	4
101010	11011011	zone ID	CRC-5	4 bit data-0

The STRM_STOP command (or the repeated STRM_STOPs to avoid decoding failure in the backscatter sensor) is special because it is issued by the reader while a group of stream tags backscatter. STRM_STOP uses the subcarrier coding instead of Miller coding to facilitate the demodulation and timing synchronization in the stream tag.

The reader-to-tag link for STRM_STOP should employ the following parameters to realize a full duplex while a group of tags is backscattering.

- Low modulation index coded subcarrier: the subcarrier frequency is 10 kHz and forward link bitrate is 2.5 kbps (4 subcarrier cycles per bit). This is to facilitate the demodulation in a stream tag. The subcarrier adoption is to shift the downlink signal from the DC component, which is strongly suppressed by the HPF (High Pass Filter) in a backscatter sensor.
- 0° phase for data 0 and 180° phases for data 1 in the subcarrier.
- Modulation index = 0.1
- Pulse shaped with raised cosine filter with roll-off factor 1.0

STRM_STOP command shall be preceded with the 16 bits data 0.

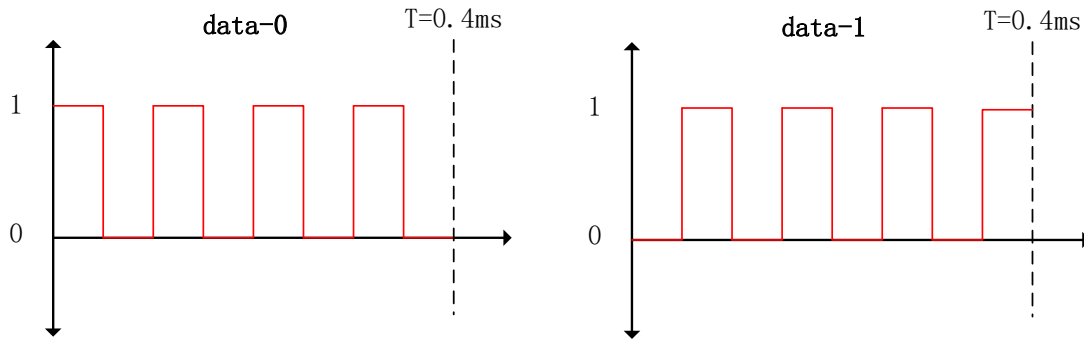

Figure 14 STRM_STOP encoding

Reference

- [1]. "ISO/IEC 18000-63, Information Technology–Radio frequency identification for item management-, Part 63 parameters for air interface communications at 860 MHz to 960 MHz type C," 2015.
- [2]. J. Mitsugi, Y. Kawakita, K. Egawa, and H. Ichikawa, "Perfectly synchronized Streaming from multiple digitally modulated backscatter sensor tags," *IEEE Journal of Radio Frequency Identification*, vol. 3, no. 3, pp. 149-156, Sept. 2019, doi: 10.1109/JRFID.2019.2914246.
- [3]. Nitish Rajoria, Yuki Igarashi, Jin Mitsugi, Yusuke Kawakita, and Haruhisa Ichikawa, "Comparative analysis on channel allocation schemes in multiple subcarrier passive communication system," *IEICE TRANSACTIONS on Communications* vol. E98-B No.9 pp.1777-1784, (2015). doi: 10.1587/transcom.E98.B.1777.
- [4]. Kuanfeng Tang, Chao Zhang, Maodong Wang, Xu. Shengliang, Ji. Shujiang, Na Yan, Hao Min, and Jin Mitsugi. "A novel method to improve the subcarrier frequency accuracy for UHF RFID sensing system," In *IEEE RFID 2021 (Virtual Event, USA)*. pp.1-6, (2021), doi: 10.1109/RFID52461.2021.9444388.
- [5]. J. Mitsugi, Y. Kawakita and H. Ichikawa, "Full duplex backscatter communication with subcarrier synchronized decimation," *2021 IEEE Wireless Communications and Networking Conference (WCNC)*, 2021, pp. 1-6, doi: 10.1109/WCNC49053.2021.9417289.

Acknowledgement

This work includes the results of the research and development for expanding radio resources (JPJ000254) conducted in FY2021 by the Ministry of Internal Affairs and Communications.

A. Guidelines for ADXL362 configuration through Gen2 WRITE commands

a. Prerequisite

Data streaming from ADXL362 with a stream tag requires the following configuration using Gen2 memory WRITE commands. An example connection between the RFIC and ADXL362 is shown in Figure 15.

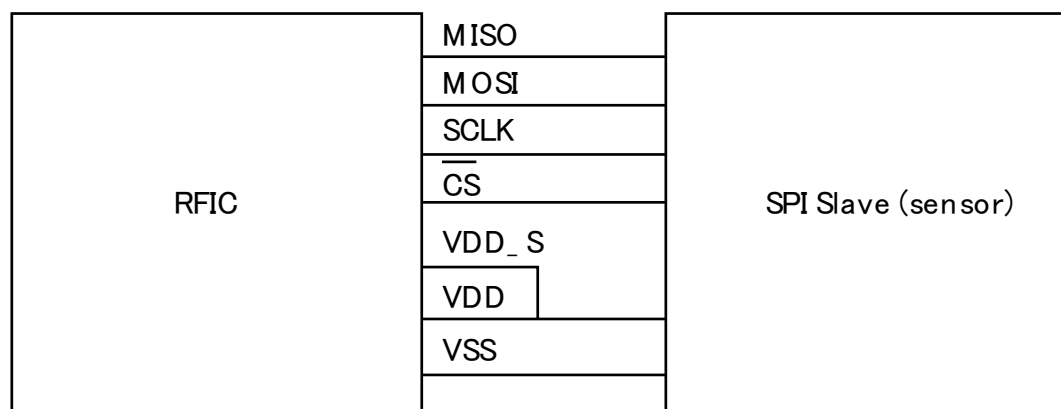

PAD name	category	Type	Output/Input	Value
MISO	SPI	Digital	Input	high : 1.6~2.5V, low : 0
MOSI		Digital	Output	high : 1.6~2.5V, low : 0
SCLK		Digital	Output	high : 1.6~2.5V, low : 0
VSS	Signal GND	Power	Input/Output	0
VDD_S	SPI output voltage regulation	Digital	Input	
VDD		Power	Output	1.4V~2V
Antenna N		RF antenna N		
Antenna P		RF antenna P		

Figure 15 RFIC, ADXL362, and Interrogator interface diagram

Before any GEN2 READ/WRITE command issuance, SPI READ/WRITE commands (which are 0 × 0B and 0 × 0A for ADXL362, respectively) should be registered to RFIC by issuing a WRITE to SPI_INST (83 H = EBV10000011) of the user memory (bank 11) to obtain the following.

WRITE	Membank	WordPtr	Data	Handle	CRC-16
11000011	11	10000011	16 bits XOR with handle	16 bits	16 bits

b. Writing to ADXL register

A Gen2 WRITE command to a specific user memory (address $0 \times 80 = \text{EBV } 10000000$) in user memory bank (bank 11) received by the RFIC passes through to the SPI using the registered WRITE command. For example, if we write a byte data point ($0 \times \text{aa}$) to a specific address of ADXL (0×77), the WRITE command is as follows.

WRITE	Membank	WordPtr	Data	Handle	CRC-16
11000011	11	10000000	16 bits ($0 \times 77\text{aa}$) XOR with Handle	16 bits	16 bits

After receiving the WRITE command, the tag responds with a delayed reply, which comprises a sequence of specified subcarriers of 43 bit duration.

Preamble	Success/Fail	Handle	CRC16
10 bits	1 bit	16 bits	16 bits
4M/BLF + 010111	0: success 1:Error		

c. Popular configuration parameters

The following is the configuration of ADXL applied in our experiments.

Description	SPI address	Data example	Note

Sensor activation threshold value setting (lower byte)	0 × 20	0 × 96	Data are the direct reading of the acceleration level that activates the MEMS sensor. 0 × 96 = 150 mg activation.
Sensor activation threshold value (higher byte)	0 × 21	0 × 00	The threshold level can be specified with 11 bit data.
Activity measurement duration	0 × 22	0 × 01	To avoid false triggering, several samples are used to distinguish between the activate and inactivate functions. The absolute time is determined by DATA/output data rate (ODR). ODR is defined in Filter Control (0 × 2C) register.
Activate/Inactivate control	0 × 27	0 × 01	Activity Enabled = 0 × 01, otherwise 0 × 00, activity is not detected. The sensor is always on and consumes power. Engaging inactivity by defining an inactive threshold level can be a viable option.
FIFO control	0 × 27	0 × 00	FIFO disabled. The sensor data are retrieved by RFIC and streamed to the interrogator by consecutively issuing SPI_READ (0 × 0B) command by RFIC.
Filter control	0 × 2C	0 × 45	The acceleration range and ODR. 0 × 05 = max 2 g and 200 Hz 0 × 45 = max 4 g and 400 Hz
Power control	0 × 2D	0 × 02	0 × 00: standby (low power consumption: 10 nA) 0 × 02: measurement

The streaming data length and Zone ID can be configured by writing the following one word data.

15	14	13	12	11	10	9	8	7	6	5	4	3	2	1	0
Starting address								# of bytes to read			RFU	Zone ID			

The addresses to retrieve data (12-bit data LSB) are as follows:

0x0E	XDATA_L	[7:0]
0x0F	XDATA_H	[7:0]
0x10	YDATA_L	[7:0]
0x11	YDATA_H	[7:0]
0x12	ZDATA_L	[7:0]
0x13	ZDATA_H	[7:0]
0x14	TEMP_L	[7:0]
0x15	TEMP_H	[7:0]

The example data to read XDATA, YDATA, ZDATA, TEMP (total $16 \times 4 = 64$ bits = 8 bytes), and Zone ID = 1 are as follows.

15	14	13	12	11	10	9	8	7	6	5	4	3	2	1	0
0 × 0E								1000				001			

This 16 bit value (0 × 0e81) should be written to STR_CNT (0 × 85) in the user memory bank with a WRITE command such that

WRITE	Membank	WordPtr	Data	Handle	CRC-16
11000011	11	10000101	16 bits (0 × 0e81) XOR with Handle	16 bits	16 bits

B. Revision History

Date	Version	Note
June 15, 2021	1.0	Initial version
July 1, 2021	1.1	Editorial and format change
July 7, 2021	1.2	Editorial change
April 15, 2022	2.0	Revision of Jupiter 2 RFIC
April 21, 2022	2.0.1	SPR can be vendor dependent.
May 7, 2022	2.0.2	After thorough proofread
May 8, 2023	2.1	Reflecting Jupiter 2 prototype test